

HYDRUS

DN 15 ... 50

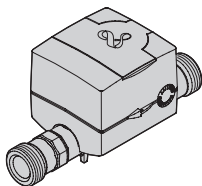

DN 50 ... 200

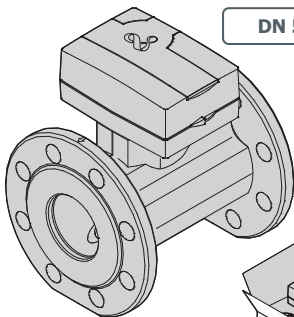

i

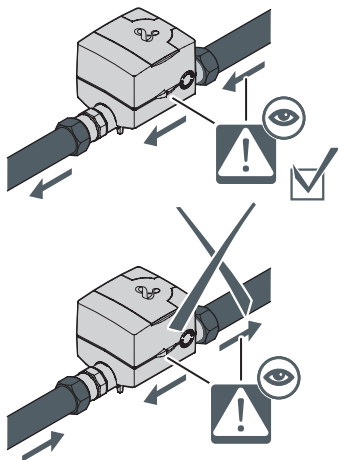

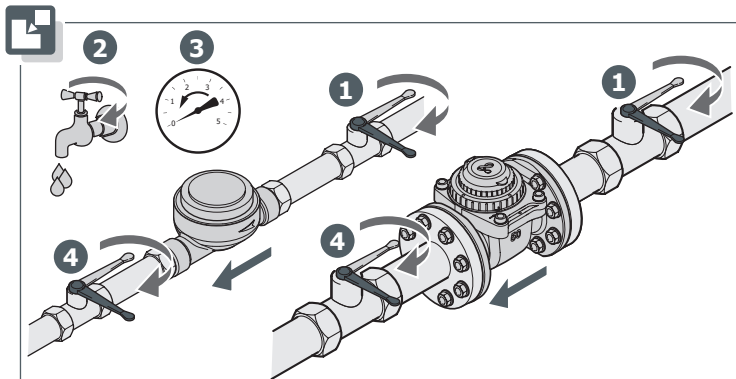
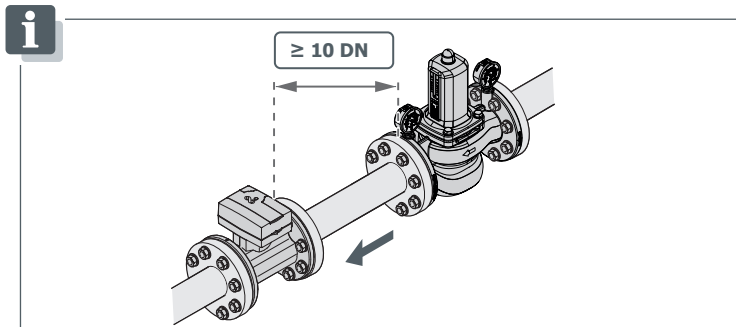
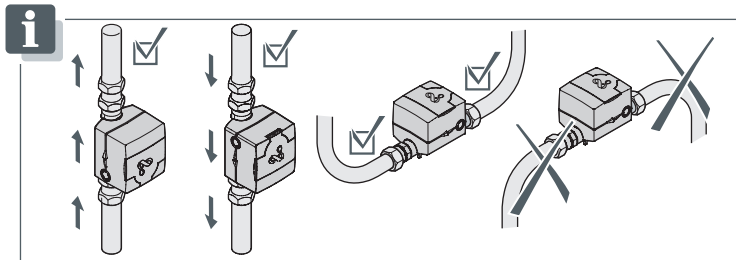

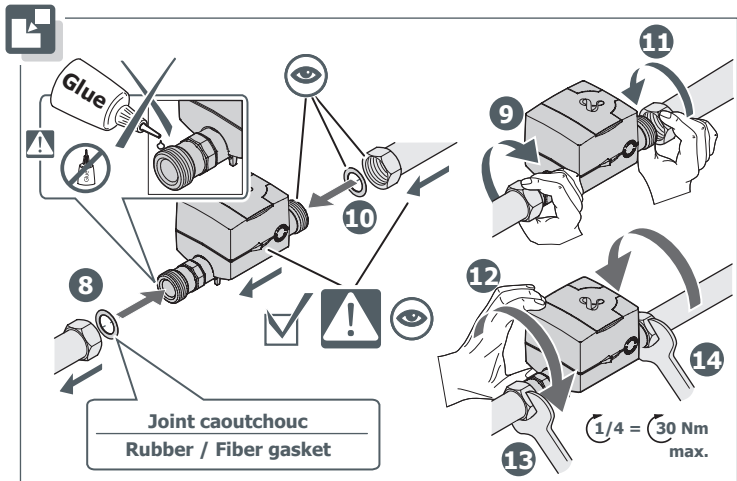
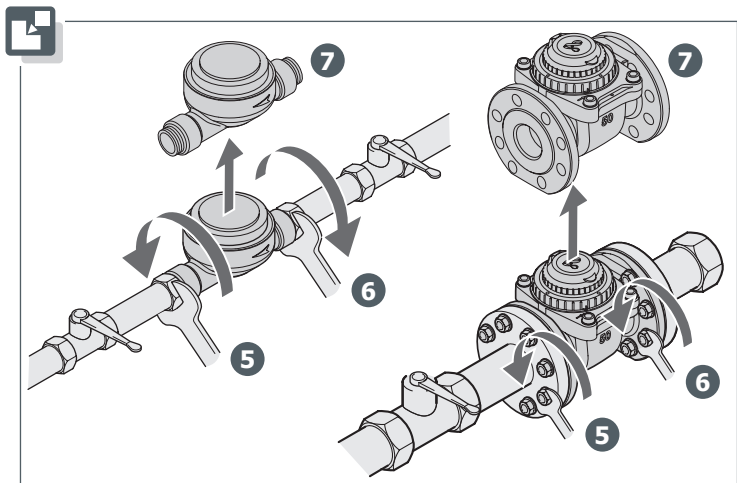

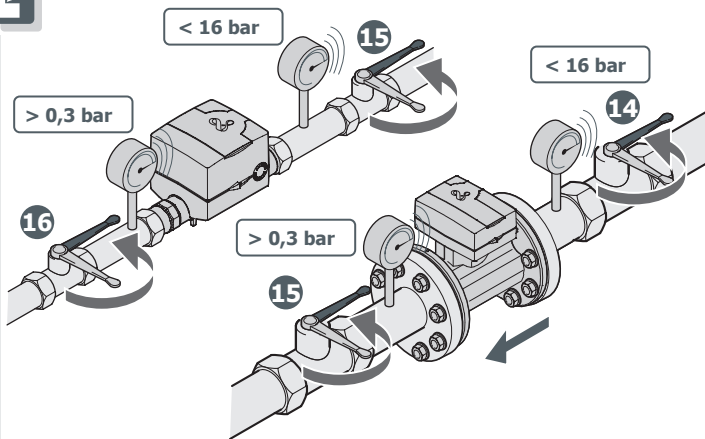
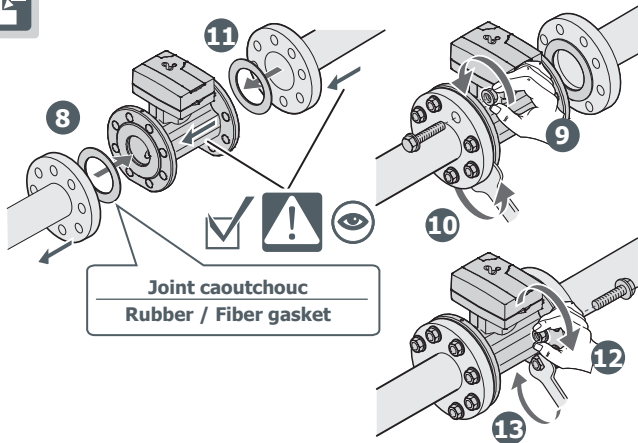



+0.1 °C ... +90 °C

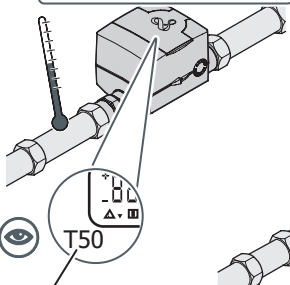

= max. 50 °C



0 °C

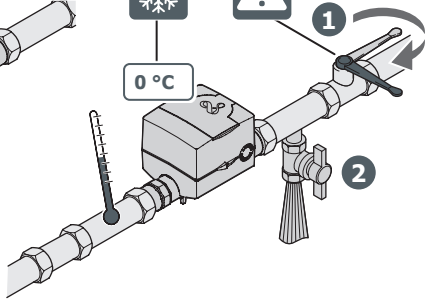

< 80 kg

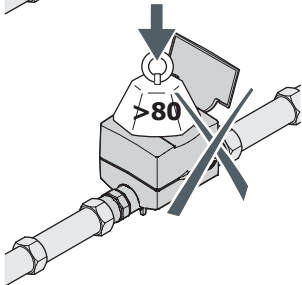
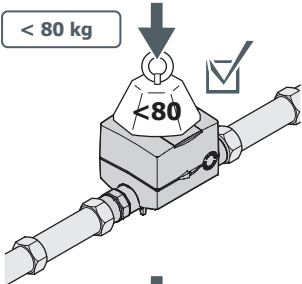

< 120 kg

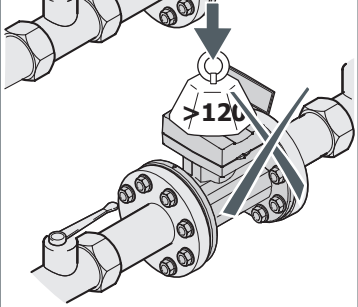
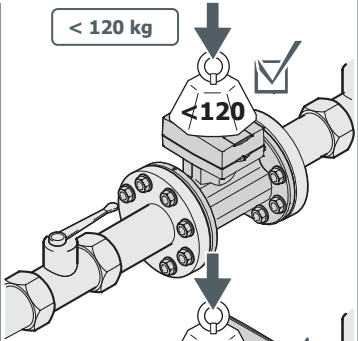

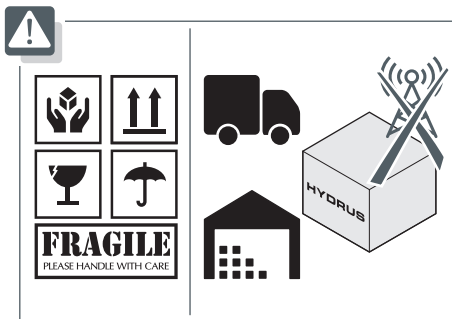
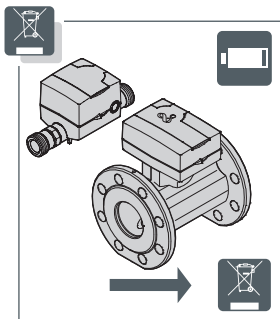
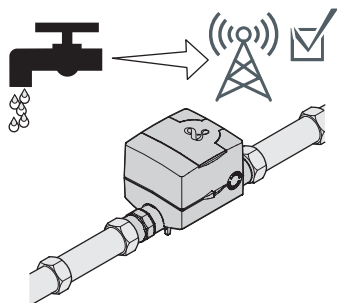
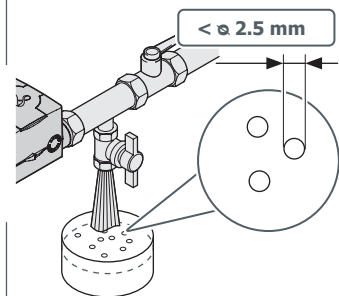
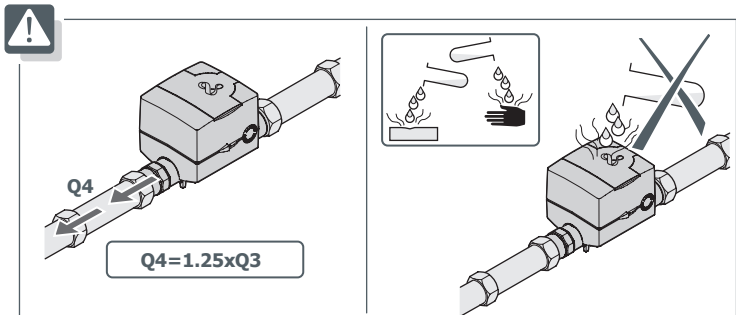

The data generated by the meter can be viewed in the display loop with system information (e.g. flow rate, volume, date, due date, medium temperature). The loops are numbered from 01 to 09.

The optical button located on the front panel enables scrolling the display loops.

To save battery lifetime, the meter switches automatically to power save mode after 4 minutes of inactivity. The display is awakened again by pressing the optical button.

After awakening, the display shows first a screen check (i.e. all symbols in the display are briefly switched on and off) and then the total volume. This remains for at least 10 seconds on the display (also when the optical button is pressed). Afterwards the display loop can be switched with the help of the optical button.

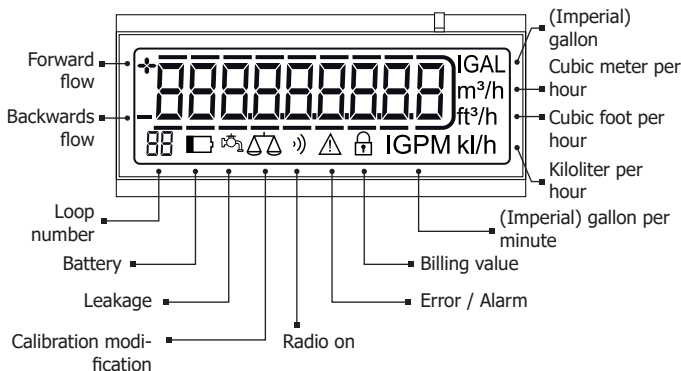

Display loop

88	Displaytest	05	Error / Alarms
01	Total volume	07	High resolution total volume
02	Battery lifetime	08	Due date / Due date volume
03	Firmware version / Checksum	09	Reverse volume
04	Current flow		

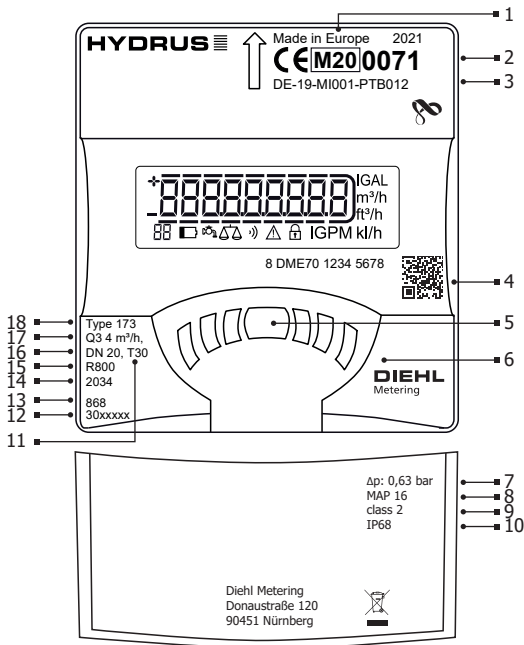

1	Conformity label	10	Protection class
2	Year of the declaration of conformity	11	Temperature class
3	Type of examination certificate number	12	Product article number
4	Meter serial number & QR code	13	Communication interfaces
5	Optical button	14	Battery lifetime *
6	Positioning assistance for optical head	15	Dynamic range
7	Pressure loss class	16	Nominal diameter
8	Maximum admissible pressure	17	Permanent flow rate
9	Metrological class	18	Type

* The meter has an option to show the battery lifetime on the display. When shown on display as well as printed on the faceplate, the displayed value should be considered in case of discrepancy. If it is only printed on faceplate, this value is considered.

Pulse outputs (open drain)

Input voltage	max. 30 V
Input current	max. 27 mA
Voltage drop at the active output	max. 2 V / 27 mA
Current through inactive output	max. 5 μ A / 30 V
Reverse current	max. 27 mA
Pulse duration, pulse break, pulse frequency	depending on device configuration (detailed description on request)

Connection diagram for passive evaluation devices (e.g. PLC)

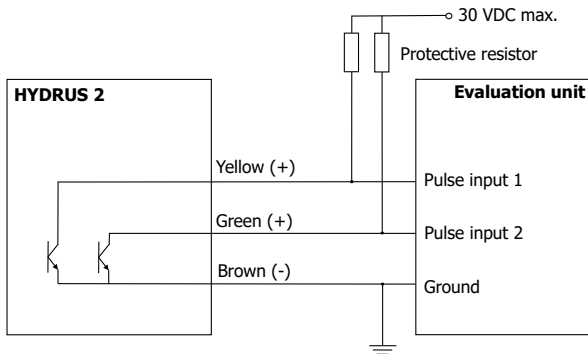

The pulse outputs of the HYDRUS are wired as open-drain, i.e. there is no current limitation internally in the meter. In order to assure functional reliability, a protective resistor is absolutely necessary for each pulse output, taking into account the input voltage (maximum 30 V) and the input current (maximum 27 mA).

Example of calculating the protective resistor of a standard PLC with 24 VDC and input current 24 mA:

$$R = U/I = 24 \text{ V} / 24 \text{ mA} = 1 \text{ k}\Omega$$

Cable pin assignment

The Radio/L-Bus/Pulse, Pulse/Pulse and M-Bus/Pulse/Pulse versions of the meter are supplied with a 1.5 m 2/3/4/5-wire connecting cable with wire end ferrules.

	Radio/ L-Bus/ Pulse	Pulse/ Pulse	M-Bus/ Pulse/ Pulse	M-Bus	4-Wire Pulse
M-Bus			x	x	
Pulse, Output 1		x	x		x
Pulse, Output 2	x	x	x		x
L-Bus	x				

Connection (network name)

GND	brown	brown	brown		brown
Pulse 1 or L-Bus	yellow	yellow	yellow		white
Pulse 2	green	green	green		yellow
M-Bus 1			white	white	
M-Bus 2			blue	blue	
Manipulation / Tampering					green
Number of Wires	3	3	5	2	4



Never connect the external M-Bus to the pulse output of the meter! It will destroy the pulse output and lead to the loss of all factory warranty claims.

Radio specifications

Sending intervals	Every 14 ... 256 seconds (variable, according to 0.1 duty cycle (min. 14 seconds); depending on protocol length and programming)
434 MHz frequency band	Transmission power (EN 300 220-2 V3.2.1): 10 mW e.r.p.
868 MHz frequency band	Transmission power (EN 300 220-2 V3.2.1): 25 mW e.r.p.

Venting



In the event that complete venting of the meter is not possible, please install the meter at an angle of 45°!

Open Source Software Notice

This product contains open source software components.

The use and distribution of any open source software is governed by respective terms and conditions of the applicable open source license. By using this product, you acknowledge that you have reviewed such license terms and notices, and you agree to be obliged by these terms.

Please insure that you get yourself familiar with the licenses terms and conditions before using this product. The complete license terms are available in the DIEHL Metering Download-center:

<https://www.diehl.com/metering/en/support-center/download-center/>

If you have any questions regarding open source software used in this product, please contact DIEHL Metering support:

oss-dmde@diehl.com

Die vom Zähler erzeugten Daten können auf verschiedenen, in Schleifen angeordneten Anzeigen mit Systeminformationen (z. B. Durchfluss, Volumen, Datum, Stichtagsdatum, Medientemperatur) abgelesen werden. Die Schleifen sind mit 01 bis 09 nummeriert.

Mithilfe des optischen Tasters auf dem vorderen Bedienfeld kann durch die einzelnen Schleifen gewechselt werden.

Um die Lebensdauer der Batterie zu verlängern, schaltet der Zähler nach 4 Minuten Inaktivität automatisch in den Energiesparmodus. Durch Drücken der optischen Taste wird die Anzeige wieder aktiviert.

Nach der Aktivierung wird zunächst eine Prüfung der Anzeige durchgeführt (d. h. alle Symbole auf der Anzeige werden kurz ein- und ausgeschaltet) und anschließend das Gesamtvolumen angezeigt. Dies wird mindestens 10 Sekunden lang auf der Anzeige angezeigt (auch wenn die optische Taste gedrückt wird). Anschließend kann mithilfe der optischen Taste die Anzeigeschleife gewählt werden.

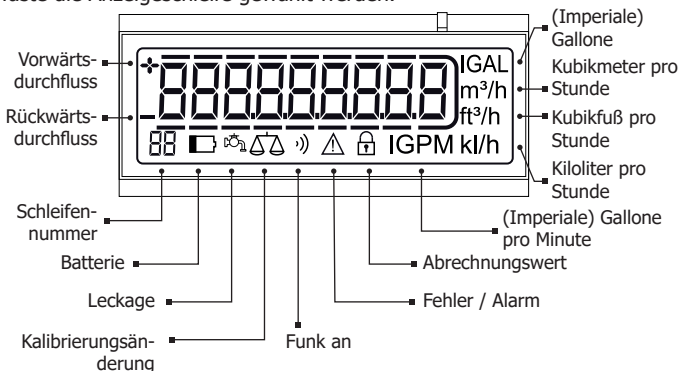

Displayschleife

88	Displaytest	05	Fehler / Alarme
01	Gesamtvolumen	07	Hochauflösendes Gesamtvolumen
02	Batterielebensdauer	08	Stichtag / Stichtagsvolumen
03	Firmware-Version / Checksumme	09	Rückflussvolumen
04	Aktueller Durchfluss		

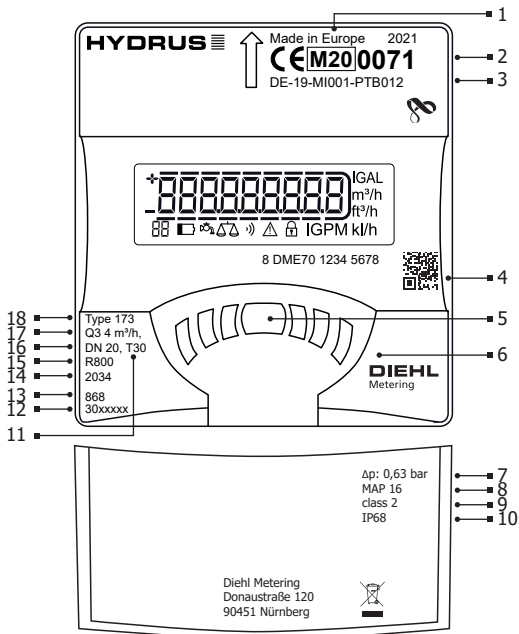

1	CE-Kennzeichnung	10	Schutzklasse
2	Jahr der Konformitätserklärung	11	Temperaturklasse
3	Art der Prüfbescheinigungsnummer	12	Artikelnummer des Produkts
4	Seriennummer & QR-Code des Messgeräts	13	Kommunikationsschnittstellen
5	Optischer Taster	14	Batterielebensdauer *
6	Positionierungshilfe für Optokopf	15	Dynamikbereich
7	Druckverlustklasse	16	Nenndurchmesser
8	Maximal zulässiger Druck	17	Dauerdurchfluss
9	Metrologische Klasse	18	Typ

* Das Messgerät verfügt über eine Option zur Anzeige der Batterielebensdauer auf dem Display. Wenn der Wert sowohl auf dem Display angezeigt wird als auch auf der Frontplatte aufgedruckt ist, sollte der angezeigte Wert im Falle einer Abweichung berücksichtigt werden. Wenn der Wert nur auf der Frontplatte aufgedruckt ist, wird dieser Wert berücksichtigt.

Impulsausgänge (Open drain)

Eingangsspannung	max. 30 V
Eingangsstrom	max. 27 mA
Spannungsabfall am aktiven Ausgang	max. 2 V / 27 mA
Strom durch inaktiven Ausgang	max. 5 μ A / 30 V
Rückwärtsstrom	max. 27 mA
Impulsdauer, Impulspause, Impulsfrequenz	abhängig von der Gerätekonfiguration ausführliche Beschreibung auf Nachfrage)

Anschlussplan für passive Auswertegeräte (z. B. SPS)

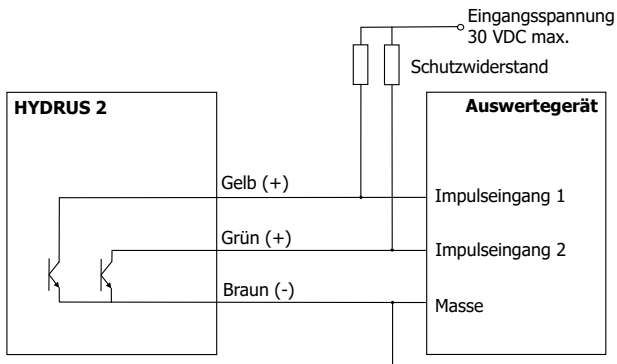

Die Pulsausgänge des HYDRUS sind als Open-Drain beschaltet, d.h. es erfolgt intern im Zähler keine Strombegrenzung. Um diese Pulsfunktion zu gewährleisten ist ein Schutzwiderstand je Pulsausgang zwingend erforderlich unter Berücksichtigung der Eingangsspannung (maximal 30 V) und des Eingangsstroms (maximal 27 mA).

Beispiel zur Berechnung des Schutzwiderstandes einer Standard SPS mit 24 VDC und Eingangsstrom 24 mA:

$$R = U/I = 24 \text{ V} / 24 \text{ mA} = 1 \text{ k}\Omega$$

Kabel Anschlussbelegung

Der Zähler wird bei Funk/L-Bus/Puls, Puls/Puls, M-Bus/Puls/Puls - Variante mit einem 1,5 m langen, 2- / 3- / 4- / 5-adrigen Anschlusskabel mit Adernhülsen geliefert.

	Funk / L-Bus / Puls	Puls / Puls	M-Bus / Puls / Puls	M-Bus	4-adrig Puls
M-Bus			x	x	
Puls Ausgang 1		x	x		x
Puls Ausgang 2	x	x	x		x
L-Bus	x				

Verbindung (Netzwerkname)

GND	braun	braun	braun		braun
Puls 1 oder L-Bus	gelb	gelb	gelb		weiß
Puls 2	grün	grün	grün		gelb
M-Bus 1			weiß	weiß	
M-Bus 2			blau	blau	
Manipulation					grün
Adernanzahl	3	3	5	2	4



Niemals den externen M-Bus an den Impulsausgang des Messgeräts anschließen! Dies zerstört den Impulsausgang und führt zum Verlust aller Werksgarantieansprüche.

Funkspezifikationen

Sendeintervalle	Alle 14 ... 256 Sekunden (variabel, entsprechend 0,1 Einschaltdauer (min. 14 Sekunden); abhängig von Protokolllänge und Programmierung)
434 MHz Frequenzbereich	Sendeleistung (EN 300 220-2 V3.2.1): 10 mW e.r.p. (effektive Strahlungsleistung)
868 MHz Frequenzbereich	Sendeleistung (EN 300 220-2 V3.2.1): 25 mW e.r.p (effektive Strahlungsleistung)

Entlüftung



Im Falle, dass eine vollständige Entlüftung des Zählers nicht möglich ist, bitte einen um 45° gekippten Einbau des Zählers vornehmen!

Hinweis zur Open Source Software

Dieses Produkt enthält Komponenten einer Open Source Software.

Die Nutzung und Verbreitung jeder Open Source Software unterliegt den AGB der betreffenden Open-Source-Lizenz. Mit der Nutzung des Produkts bestätigen Sie, dass Sie die Lizenzbedingungen und -hinweise eingesehen haben und erklären, dass Sie mit diesen Bedingungen einverstanden sind.

Bitte vergewissern Sie sich, dass Sie sich mit den Lizenzbedingungen vertraut gemacht haben, bevor Sie dieses Produkt verwenden. Die vollständigen Lizenzbedingungen finden Sie im DIEHL Metering Download-Center: <https://www.diehl.com/metering/de/support-center/download-center/>

Wenn Sie Fragen zu der im Produkt verwendeten Open Source Software haben, wenden Sie sich bitte an den Support von DIEHL Metering:

oss-dmde@diehl.com

Les données recueillies par le compteur sont affichées dans les menus d'information (exemple : débit, volume, date, date d'échéance, température ambiante). Les menus sont numérotés de 01 à 09.

La touche optique située sur le totalisateur (sous l'écran LCD) permet de faire défiler les menus.

Afin de préserver la pile, le compteur passe automatiquement en mode économie d'énergie après 4 minutes d'inactivité. L'affichage est réactivé en appuyant sur la touche optique.

Après réactivation, l'écran affiche d'abord le test d'affichage (c'est-à-dire que tous les symboles de l'écran sont brièvement allumés puis éteints), ensuite le volume total. Celui-ci reste affiché pendant au moins 10 secondes (même si l'on appuie sur la touche optique). Le menu d'information peut ensuite être commuté à l'aide de la touche optique.

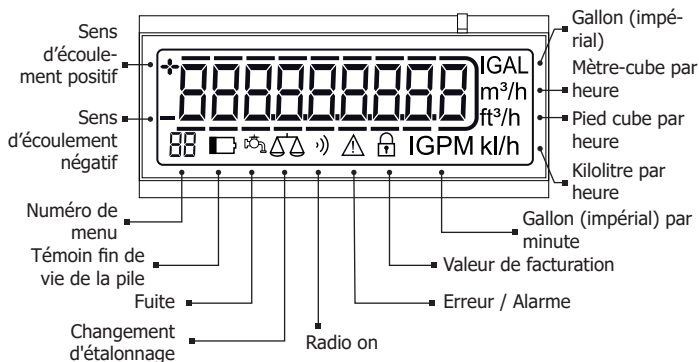

Menus de défilement

88	Test écran LCD	05	Codes d'erreur
01	Volume total	07	Volume total haute résolution
02	Autonomie de la pile	08	Date d'échéance / Volume total à date d'échéance
03	Version du firmware / Somme de contrôle du firmware	09	Volume négatif
04	Débit instantané		

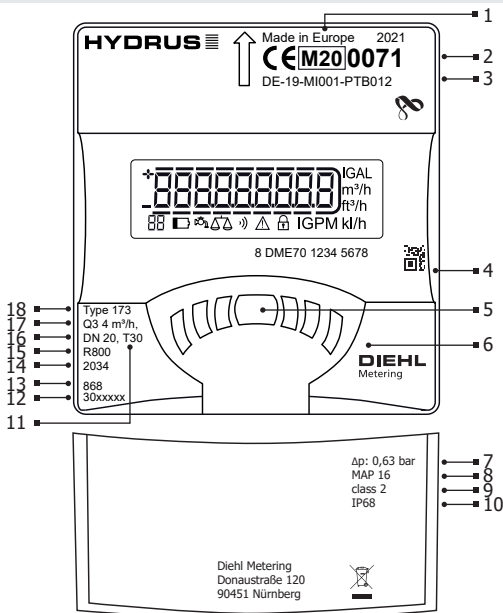

1	Marquage de conformité CE	10	Classe de protection (IP)
2	Millésime de fabrication	11	Classe de température
3	Numéro du certificat d'examen UE de type	12	Numéro d'article du produit
4	Numéro de série du compteur et code QR	13	Type de connectivité
5	Touche optique / communication IrDa	14	Année de fin de vie de la batterie *
6	Support de position pour la tête optique	15	Classe métrologique R selon la position (H / V)
7	Classe de perte de charge	16	Diamètre nominal
8	Pression maximale admissible	17	Débit permanent Q3 en m³/h
9	Classe métrologique	18	Numéro de famille du compteur

* Le lecteur a la possibilité d'afficher la durée de vie de la pile sur l'écran. Lorsqu'elle est affichée sur l'écran et imprimée sur la plaque frontale, la valeur affichée doit être prise en compte en cas de divergence. Si elle n'est imprimée que sur l'interface, c'est cette valeur qui est prise en compte.

Sorties d'impulsion (open drain)

Tension d'entrée	max. 30 V
Intensité de courant d'entrée	max. 27 mA
Chute de tension à la sortie active	max. 2 V / 27 mA
Courant traversant la sortie inactive	max. 5 μ A / 30 V
Courant inverse	max. 27 mA
Durée d'impulsion, pause d'impulsion, fréquence d'impulsion	en fonction de la configuration de l'appareil (description détaillée sur demande)

Schéma de connexion pour les automates programmables industriels (par ex. API)

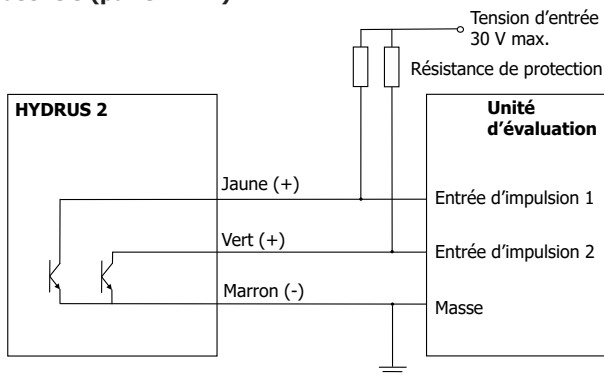

Les sorties impulsions de l'HYDRUS 2 sont connectées en open-drain (collecteur ouvert), c'est-à-dire qu'il n'y a pas de limitation de courant interne au compteur.

Pour garantir l'impulsion, une résistance de protection est impérativement nécessaire pour chaque sortie impulsion.

Il faut également prendre en compte la tension d'entrée (30 V maximum) et le courant d'entrée (27 mA maximum).

Exemple de calcul de la résistance de protection d'un API standard avec 24 VDC et un courant d'entrée de 24 mA :

$$R = U/I = 24 \text{ V} / 24 \text{ mA} = 1 \text{ k}\Omega$$

Affectations des bornes du câble

Pour les variantes Radio/L-bus/Impulsion, Impulsion/Impulsion, M-bus/Impulsion/Impulsion, le compteur est fourni avec un câble de raccordement d'une longueur de 1,5 m à 2 / 3 / 4 / 5 conducteurs avec embouts.

	Radio / L-bus / Impul- sion	Impul- sion / Impul- sion	M-bus / Impulsion / Impulsion	M-bus	Impulsion à 4 conduc- teurs
M-bus			x	x	
Sortie impul- sionnelle 1		x	x		x
Sortie impul- sionnelle 2	x	x	x		x
L-bus	x				
Connexion (nom du réseau)					
Terre	brun	brun	brun		brun
Impulsion 1 ou L-bus	jaune	jaune	jaune		blanc
Impulsion 2	vert	vert	vert		jaune
M-bus 1			blanc	blanc	
M-bus 2			bleu	bleu	
Manipulation					vert
Nombre de conducteurs	3	3	5	2	4



Ne jamais raccorder le M-bus externe à la sortie impulsionnelle de l'instrument de mesure ! Cela détruit la sortie impulsionnelle et provoque une perte de tous les droits découlant de la garantie d'usine.

Spécifications radioélectriques

Intervalles d'émission	Toutes les 14 à 256 secondes (variable, équivaut à 0,1 facteur de marche (min. 14 secondes) ; en fonction de la longueur du protocole et de la programmation)
Gamme de fréquences 434 MHz	Puissance d'émission (EN 300 220-2, V3.2.1) : 10 mW ERP (puissance apparente rayonnée)
Gamme de fréquences 868 MHz	Puissance d'émission (EN 300 220-2, V3.2.1) : 25 mW ERP (puissance apparente rayonnée)

Purge



Dans le cas où une purge complète du compteur s'avère impossible, prière de monter le compteur avec une inclinaison de 45° !

Remarque relative au logiciel Open Source

Ce produit contient des composants d'un logiciel open source.

L'utilisation et la distribution de tout logiciel open source sont soumises aux termes et conditions de la licence open source correspondante. En utilisant le produit, vous reconnaissez avoir lu et accepté d'être lié par les termes et conditions de la licence.

Veillez vous assurer de bien avoir pris connaissance des conditions de licence avant d'utiliser ce produit. Les conditions de licence complètes sont disponibles dans le centre de téléchargement DIEHL Metering :

<https://www.diehl.com/metering/fr/assistance/centre-de-téléchargement/>

Si vous avez des questions sur le logiciel open source utilisé dans le produit, veuillez contacter l'assistance de DIEHL Metering :

oss-dmde@diehl.com

Los datos generados por el contador se pueden ver en el bucle de pantalla con información del sistema (p. ej. caudal, volumen, fecha, vencimiento, temperatura media). Los bucles están numerados del 01 al 09.

El sensor óptico situado en el panel frontal permite de navegar en los bucles de pantalla.

Para aumentar la vida de la batería, el contador cambia automáticamente al modo de ahorro de energía tras 4 minutos de inactividad. La pantalla se reactiva pulsando en el sensor óptico.

Una vez activada, la pantalla muestra primero una verificación (es decir, todos los símbolos de la pantalla se encienden y se apagan brevemente) y después el volumen total. Permanece durante al menos 10 segundos en la pantalla (también cuando se pulsa el sensor óptico). Después se puede cambiar el bucle de pantalla con la ayuda del sensor óptico.

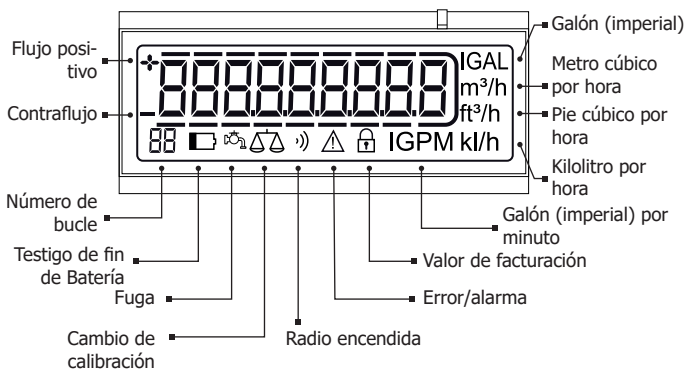

Bucle de pantalla

88	Prueba de pantalla	05	Códigos de Errores / Alarmas
01	Volumen total	07	Volumen total alta resolución
02	Duración de la batería	08	Fecha Vencimiento / Volumen total a fecha de vencimiento
03	Versión de firmware / Suma de control del firmware	09	Volumen en contraflujo
04	Caudal instantáneo		

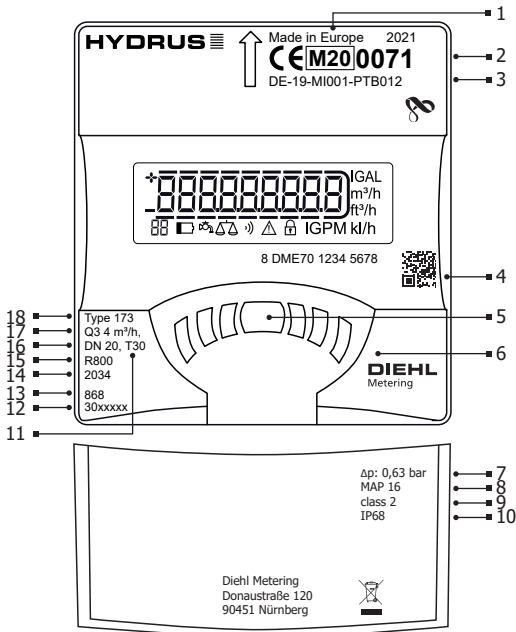

1	Marcado de conformidad	10	Clase de protección
2	Año de fabricación	11	Clase de temperatura
3	Número de certificado de examen de tipo	12	Código de producto
4	Número de serie del contador y código QR	13	Interfaces de comunicación
5	Sensor óptico / comunicación IrDa	14	Año de fin de vida de batería *
6	Soporte de posicionamiento para cabezal óptico	15	Clase metrológica R según posición (H/V)
7	Clase de pérdida de presión	16	Diámetro nominal
8	Presión máxima admisible	17	Caudal permanente
9	Clase metrológica	18	Tipo de la familia del contador

* El medidor tiene una opción para mostrar la vida útil de la batería en la pantalla. Si se muestra tanto en la pantalla como en la placa frontal, en caso de discrepancia debe tenerse en cuenta el valor mostrado. Si sólo está impreso en la placa frontal, se considerará este valor.

Salidas de impulsos (drenaje abierto)

Tensión de entrada	máx. 30 V
Corriente de entrada	máx. 27 mA
Caída de tensión en la salida activada	máx. 2 V / 27 mA
Corriente por la salida desactivada	máx. 5 μ A / 30 V
Corriente invertida	máx. 27 mA
Duración, pausa y frecuencia de impulsos	en función de la configuración del aparato (descripción detallada bajo demanda)

Esquema de conexión para autómatas programables (p. ej. PLC)

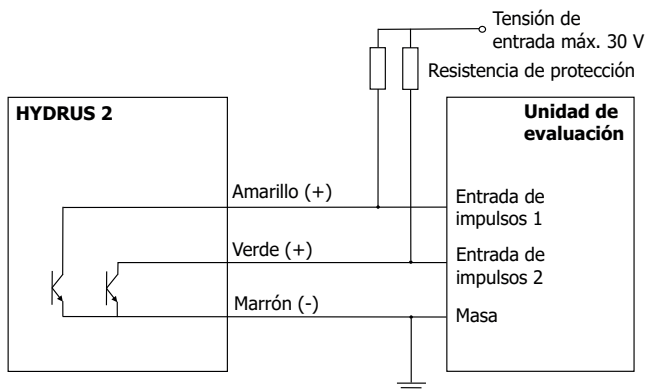

Las salidas de impulsos HYDRUS están conectadas en drenaje abierto, es decir, no hay limitación interna de la corriente del contador.

Para garantizar el impulso, se requiere una resistencia de protección para cada salida de impulso. También hay que tener en cuenta la tensión de entrada (30 V máximo) y la corriente de entrada (27 mA máximo).

Ejemplo de cálculo de la resistencia de protección de un PLC estándar con 24 V CC y corriente de entrada de 24 mA:

$$R = U/I = 24 \text{ V} / 24 \text{ mA} = 1 \text{ kOhm}$$

Asignación de conexiones de cable

Para las variantes radio/bus L/impulso, impulso/impulso, bus M/impulso/impulso, el contador se suministra con un cable de conexión de 1,5 m de longitud y 2/3/4/5 hilos con virolas de cable.

	Radio / bus L / impulso	Impulso / impulso	Bus M / impulso / impulso	Bus M	Impulso en 4 hilos
Bus M			x	x	
Impulso en salida 1		x	x		x
Impulso en salida 2	x	x	x		x
Bus L	x				

Conexión (nombre de red)

GND	marrón	marrón	marrón		marrón
Impulso 1 o bus L	amarillo	amarillo	amarillo		blanco
Impulso 2	verde	verde	verde		amarillo
Bus M 1			blanco	blanco	
Bus M 2			azul	azul	
Manipulación					verde
Número de hilos	3	3	5	2	4



¡No conectar nunca el bus M externo en la salida de impulsos del aparato de medición! Ello origina desperfectos en la salida de impulsos y la pérdida de todos los derechos de garantía de fábrica.

Especificaciones de la radiocomunicación

Intervalos de emisión	Cada 14...256 segundos (variable, correspondiente a una duración de conexión de 0,1 (mín. 14 segundos); en función de la longitud del protocolo y de la programación))
Rango de frecuencia de 434 MHz	Potencia de emisión (EN 300 220-2 V3.2.1): 10 mW e.r.p. (potencia de radiación efectiva)
Rango de frecuencia de 868 MHz	Potencia de emisión (EN 300 220-2 V3.2.1): 25 mW e.r.p. (potencia de radiación efectiva)

Ventilación



¡En caso de que no sea posible una ventilación completa del contador; por favor, realice el montaje del contador con una inclinación de 45°!

Indicación sobre el software de código abierto

Este producto contiene componentes de software de código abierto.

El uso y distribución de cualquier software de código abierto está sujeto a las CGC de la licencia de código abierto correspondiente. Al utilizar el producto, usted reconoce haber leído y estar de acuerdo con las condiciones e indicaciones de la licencia.

Asegúrese de estar familiarizado con las condiciones de la licencia antes de utilizar este producto. Las condiciones completas de la licencia se pueden encontrar en el Centro de descarga de medición DIEHL:

<https://www.diehl.com/metering/es/centro-de-servicio-tecnico/download-center/>

Si tiene alguna pregunta sobre el software de código abierto utilizado en el producto, póngase en contacto con el centro de servicio técnico de DIEHL Metering:

oss-dmde@diehl.com

Os dados gerados pelo medidor podem ser visualizados no loop do display com as informações do sistema (por exemplo, vazão, volume, data, data de vencimento, temperatura média).

Os loops estão numerados de 01 a 09.

O sensor óptico situado no painel permite a rodar os loops do display.

Para economizar a bateria, o medidor passa automaticamente ao modo standby após 4 minutos de inatividade. Para reativar o display, pressionar o sensor óptico.

Depois de reativado, o display exibe primeiramente uma verificação de tela (ou seja, todos os símbolos do display são brevemente ligados e desligados) e depois, o volume total. Esta apresentação permanece por pelo menos 10 segundos no display (e também quando o sensor óptico é atuado). Depois disso, o loop do display pode ser alterado com o auxílio do sensor óptico.

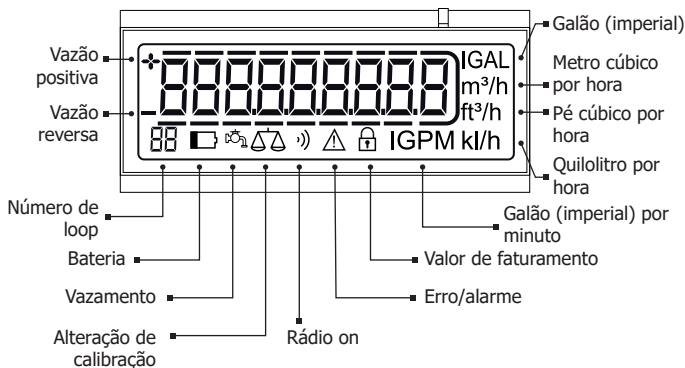

Loop do display

88	Teste de display	05	Código de Erros/Alarmes
01	Volume total	07	Volume total de alta resolução
02	Vida útil da bateria	08	Data de vencimento/Volume na data de vencimento
03	Versão do Firmware / Controle do Firmware	09	Volume reverso
04	Vazão instantânea		

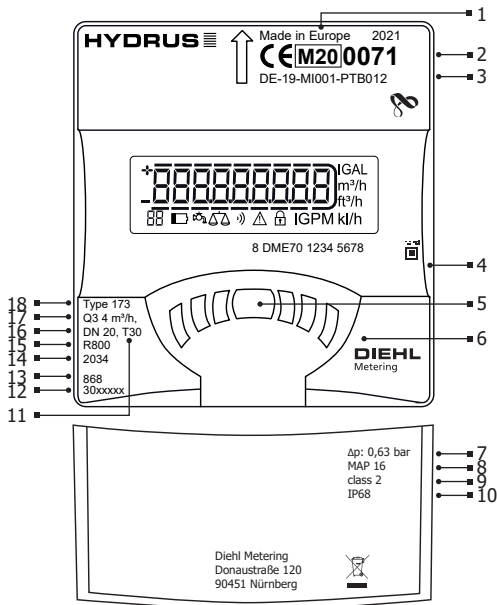

1	Rótulo de conformidade	10	Classe de proteção
2	Ano de fabricação	11	Classe de temperatura
3	Número do certificado de exame de tipo	12	Código do produto
4	Número de série do medidor e código QR	13	Interfaces de comunicação
5	Sensor óptico	14	Ano de fim de vida útil da bateria *
6	Suporte de posicionamento da leitor óptica	15	Classe metrologica R de acordo com a posição (H / V)
7	Classe de perda de pressão	16	Diâmetro nominal
8	Pressão máxima admissível	17	Taxa de vazão permanente
9	Classe metroológica	18	Tipo de família

* O medidor tem uma opção para mostrar a vida útil da bateria no visor. Quando mostrado no visor e também impresso no painel frontal, o valor exibido deve ser considerado em caso de discrepância. Se for impresso apenas no painel frontal, esse valor será considerado.

Recursos de saídas de pulso (open drain)

Tensão de entrada	máx. 30 V
Corrente de entrada	máx. 27 mA
Queda de tensão na saída ativa	máx. 2 V / 27 mA
Corrente através de saída inativa	máx. 5 μ A / 30 V
Corrente reversa	máx. 27 mA
Duração do pulso, pausa do pulso, frequência do pulso	dependente da configuração do aparelho (descrição detalhada a pedido)

Esquema de ligações para aparelhos de avaliação passivos (p. ex., SPS)

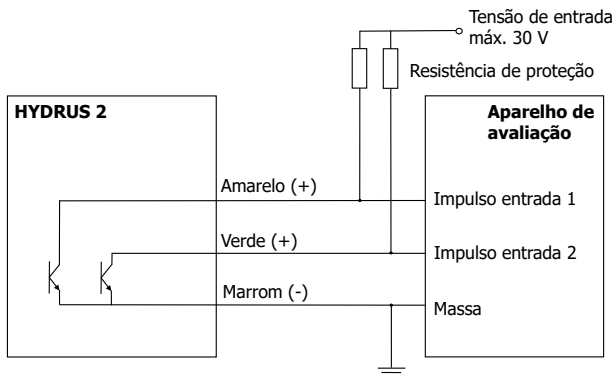

As saídas de impulsos do HYDRUS estão conectadas como open-drain, isto é, não ocorre nenhuma limitação interna no medidor. Para garantir esta função impulsos, é imprescindivelmente necessária uma resistência de proteção para cada saída de impulsos, tendo em conta a tensão de entrada (máximo 30 V) e a corrente de entrada (máximo 27 mA).

Exemplo de cálculo da resistência de proteção de um SPS padrão com 24 VDC e corrente de entrada 24 mA:

$$R = U/I = 24 \text{ V} / 24 \text{ mA} = 1 \text{ k}\Omega$$

Pinagem do cabo

Na variante rádio/bus L/pulso, pulso/pulso, bus M/pulso/pulso, o medidor é fornecido com um cabo de conexão de 1,5 m de comprimento de 2/3/4/5 fios com terminais de ilhós.

	Rádio / Bus L / Pulso	Pulso / Pulso	Bus M / Pulso / Pulso	Bus M	Pulso 4 fios
Bus M			x	x	
Saída de pulso 1		x	x		x
Saída de pulso 2	x	x	x		x
Bus L	x				

Conexão (nome da rede)

GND	marrom	marrom	marrom		marrom
Pulso 1 ou bus L	amarelo	amarelo	amarelo		branco
Pulso 2	verde	verde	verde		amarelo
Bus M 1			branco	branco	
Bus M 2			azul	azul	
Manipulação					verde
Número de fios	3	3	5	2	4



Nunca conectar o M-Bus externo à saída de pulso do medidor! Isto danifica a saída de pulso e causa a perda de todas as reivindicações de garantia de fábrica.

Especificações de rádio

Intervalos de transmissão	A cada 14 ... 256 segundos (variável, correspondendo a 0,1 vezes o ciclo de trabalho (mín. 14 segundos); dependendo da duração do protocolo e da programação)
Intervalo de frequência 434 MHz	Potência de transmissão (EN 300 220-2 V3.2.1): 10 mW e.r.p. (potência efetiva irradiada)
Intervalo de frequência 868 MHz	Potência de transmissão (EN 300 220-2 V3.2.1): 25 mW e.r.p. (potência efetiva irradiada)

Ventilação



Caso não seja possível uma ventilação completa do medidor, instale-o inclinado 45°!

Nota sobre o software Open Source

Este produto contém componentes de um software Open Source.

A utilização e distribuição de qualquer software Open Source são regidas pelos TCG da respetiva licença Open Source. Ao utilizar este produto, confirma ter tomado conhecimento destas condições e notas relativamente à licença e declara concordar com estas condições.

Assegure que se familiariza com as condições da licença, antes de utilizar este produto. As condições completas da licença podem ser encontradas no DIEHL Metering Download Center:

<https://www.diehl.com/metering/en/support-center/download-center/>

Caso tenha questões relativamente ao software Open Source utilizado no produto, contacte o serviço de apoio ao cliente da DIEHL Metering:
oss-dmde@diehl.com

UK DoC PSTI SoC 173/2

**UK Declaration of Conformity**

1. Instrument model/instrument:

Type 173

2. Name and address of the manufacturer:

**Diehl Metering
Donaustrasse 120
90451 Nürnberg
Germany**

3. This declaration of conformity is issued under the sole responsibility of the manufacturer.

4. Object of the declaration:

Ultrasonic Water Meter HYDRUS

5. The object of the declaration described above is in conformity with the relevant UK statutory requirements:

2016 No. 1091	The Electromagnetic Compatibility Regulations 2016 with Amendments
2016 No. 1153	The Measuring Instruments Regulations 2016 with Amendments
2017 No. 1206	The Radio Equipment Regulations 2017 with Amendments
2012 No. 3032	The Restriction of the Use of Certain Hazardous Substances in Electrical and Electronic Equipment Regulations 2012 with Amendments

6. References to the relevant designated standards or normative documents used or references to the other technical specifications in relation to which conformity is declared:

EN 55032:2015/A11:2020	OIML R49-1:2006	EN 301 489-3 v2.1.1
EN ISO 4064-1:2017	OIML R49-2:2004	EN 300 220-2 v3.1.1
EN ISO 4064-2:2017 EN ISO 4064-3:2014	EN 62479:2010	EN 62368-1:2014/AC:2015
EN ISO 4064-5:2017	EN 62311:2008	EN IEC 63000:2018
	EN 301 489-1 v2.1.1	

7. The approved body NMO, Approved Body number 0126, performed type examination and issued the type examination certificate UK/0126/0326.
The approved body LNE-GMED UK., Approved Body number UKAB N° 8521, performed quality assurance of the production process and issued the certificate: N° UKCA- 39079 rev. 0

Statement of Compliance in accordance with the Product Security and Telecommunications Infrastructure Act 2022 and The Product Security and Telecommunications Infrastructure (Security Requirements for Relevant Connectable Products) Regulations 2023 ("PSTI Regs")

- a. The product described above complies with the relevant security requirements specified in Schedule 1 of the PSTI Regs.
- b. Factory default state: not applicable
- c. Defined support period for the product current from the date of supply of the product: please see product warranty information. The firmware of the product cannot be altered. The software in the product is not able to be updated or supported via over-the-air updates.
Please note that defined support period stated herein, is only applicable to products sold in the UK.
- d. Contact point for the reporting of any security issues with the product described above:
please contact us at: metering-uk-sales@diehl.com

Signed for and on behalf of:

Nürnberg, 2024-06-25

Dr. Christof Bosbach
President of the Division Board
Diehl Metering

Reiner Edel
Member of the Division Board
Finance & Administration

UK DoC 174/1

DIEHL
Metering

UK Declaration of Conformity

1. Instrument model/instrument:

Hydrus Type 174

2. Name and address of the manufacturer:

**Diehl Metering
Donaustrasse 120
90451 Nürnberg
Germany**

3. This declaration of conformity is issued under the sole responsibility of the manufacturer.

4. Object of the declaration:

Ultrasonic Water Meter HYDRUS

5. The object of the declaration described above is in conformity with the relevant UK statutory requirements:

2016 No. 1091	The Electromagnetic Compatibility Regulations 2016 with Amendments
2016 No. 1153	The Measuring Instruments Regulations 2016 with Amendments
2017 No. 1206	The Radio Equipment Regulations 2017 with Amendments
2012 No. 3032	The Restriction of the Use of Certain Hazardous Substances in Electrical and Electronic Equipment Regulations 2012 with Amendments

6. References to the relevant designated standards or normative documents used or references to the other technical specifications in relation to which conformity is declared:

EN 55032:2015/A11:2020	EN ISO 4064-3:2014	EN 301 489-1 v2.1.1
EN 14154-1:2005/A2:2011	EN ISO 4064-5:2017	EN 301 489-3 v2.1.1
EN 14154-2:2005/A2:2011	OIML R49-1:2006	EN 300 220-2 v3.1.1
EN 14154-3:2005/A2:2011	OIML R49-2:2004	EN 62368-1:2014/AC:2015
EN ISO 4064-1:2017	EN 62479:2010	EN IEC 63000:2018
EN ISO 4064-2:2017	EN 62311:2008	

7. The approved body NMO, Approved Body number 0126, performed type examination and issued the type examination certificate UK/0126/0325.

The approved body LNE-GMED UK., Approved Body number UKAB N° 8521, performed quality assurance of the production process and issued the certificate: N° UKCA- 39079 rev. 0

Signed for and on behalf of:

Nürnberg, 2023-07-06

	
<small>Christof Bosbach (Jun 14, 2023 14:54 GMT+2)</small>	<small>Reiner Edel (Jun 14, 2023 07:55 GMT+2)</small>
Dr. Christof Bosbach President of the Division Board Diehl Metering	Reiner Edel Member of the Division Board Finance & Administration

Mat.-Nr. 3089479 • 29/1/2025

Diehl Metering GmbH

Industriestrasse 13

91522 Ansbach

Phone: +49 981 1806-0

Fax: +49 981 1806-615

info-dmde@diehl.com



www.diehl.com/metering